



Presses & Automation
SINCE 1975



AZ-SF3
Servo Straightener feeder



AZ-SF3

Servo Motorized Straightener & Feeder



- Workspace saving: Save up to 30% space compared to a traditional feed line
- Omron Servo Driven
- Pneumatic Pilot Release
- Up to 1000 job storage
- Motorized Straightener & Feeder combination units
- Motorized pass-line adjustment
- 4140 Steel rolls hardened to 58-64HRC
- Optional Sequential feeding
- Optional GAG Outputs based on sequence





AZ-SF

Servo Motorized Straightener & Feeder

Model→ Parameter↓	Unit	AZ-SF-400	AZ-SF-500	AZ-SF-600	AZ-SF-800
Min width	INCH	2,750			
Max Width	INCH	15,75	19,625	23,625	31,50
Thickness MIN	INCH	0,020			
Thickness MAX	INCH	DSF1: 0,125" DSF2 : 0,1875" DSF3 : 0,250"			
Pass-line (Motorized)	INCH	43.25 to 51.25 (customizable)			
Feeding rolls diameter	INCH	3,465			
Starighthener rolls diameter	INCH	2,677			
Straightener rolls configuration		4 top 3 bottom			
Pilot Release		Pneumatic			
Max speed	INCH/S	15,75			





AZ-SF3

Servo Motorized Straightener & Feeder



- Space Saving line allows to reduce line length of more than 30% than typical line
- Combine any of our Decoiler to integrate the whole line

- Pneumatic coil threading features
- High quality hardened servo/straightener rolls
- Pneumatic pilot release features
- Double handles for straightener adjustment
- Pneumatic feeder release & Pneumatic Straightener release
- Electric pass line adjustment +/-100mm
- Accuracy of +/- 0.003"
- Straightener configurations : 4 top 3 bottom
- Several controller options such as feed output controller, custom counter, etc.
- High quality timing belt design
- Optional Oiling system
- Optional Advanced controller

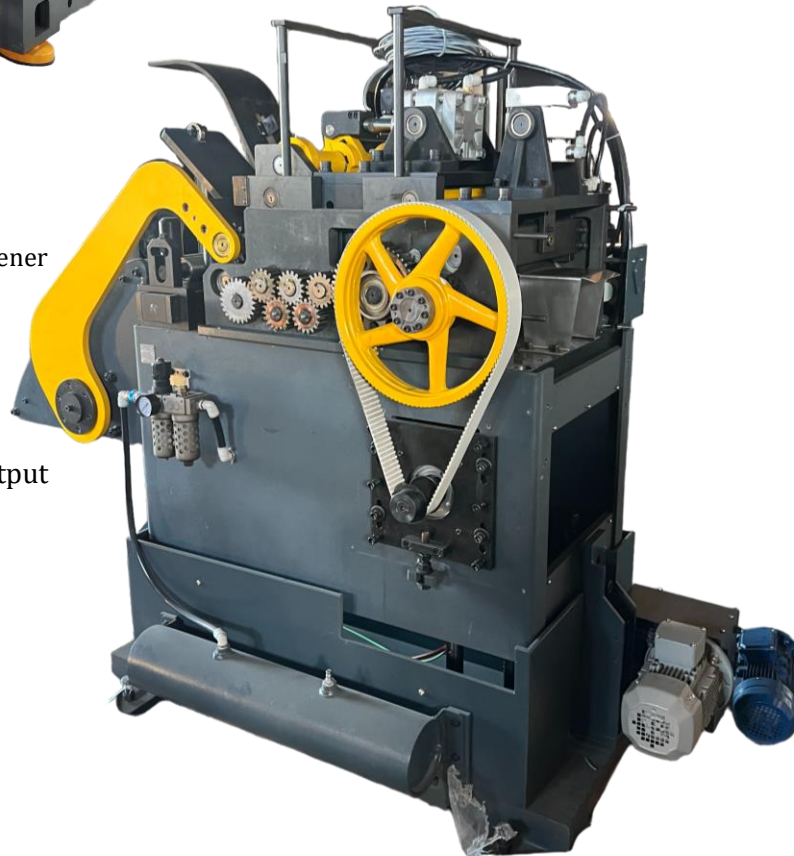



AZ-SF2

Servo Motorized Straightener & Feeder

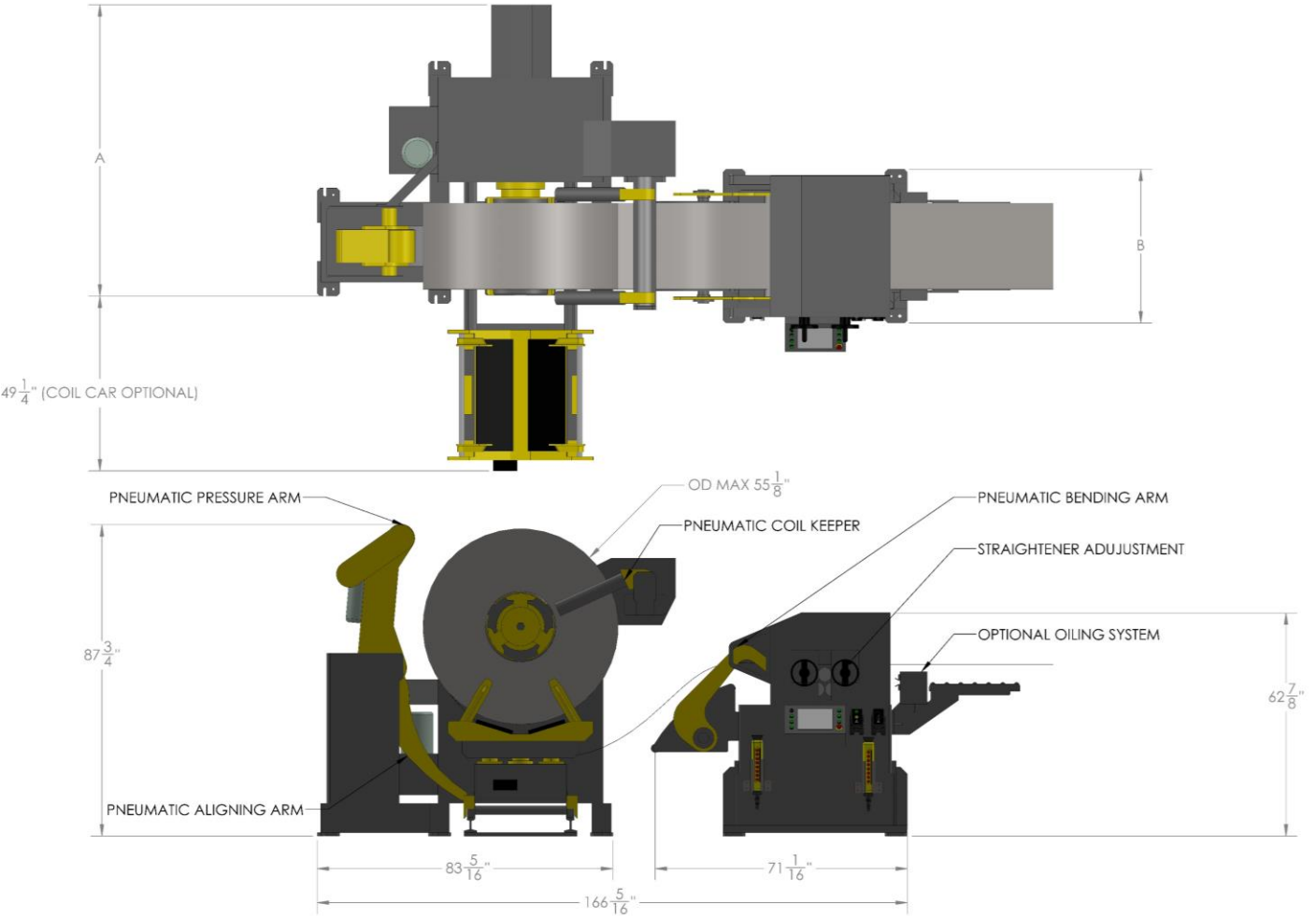



AZ-SF3

Straightening & feeding capacity

Straightening Capacities for AZ-SF3 models

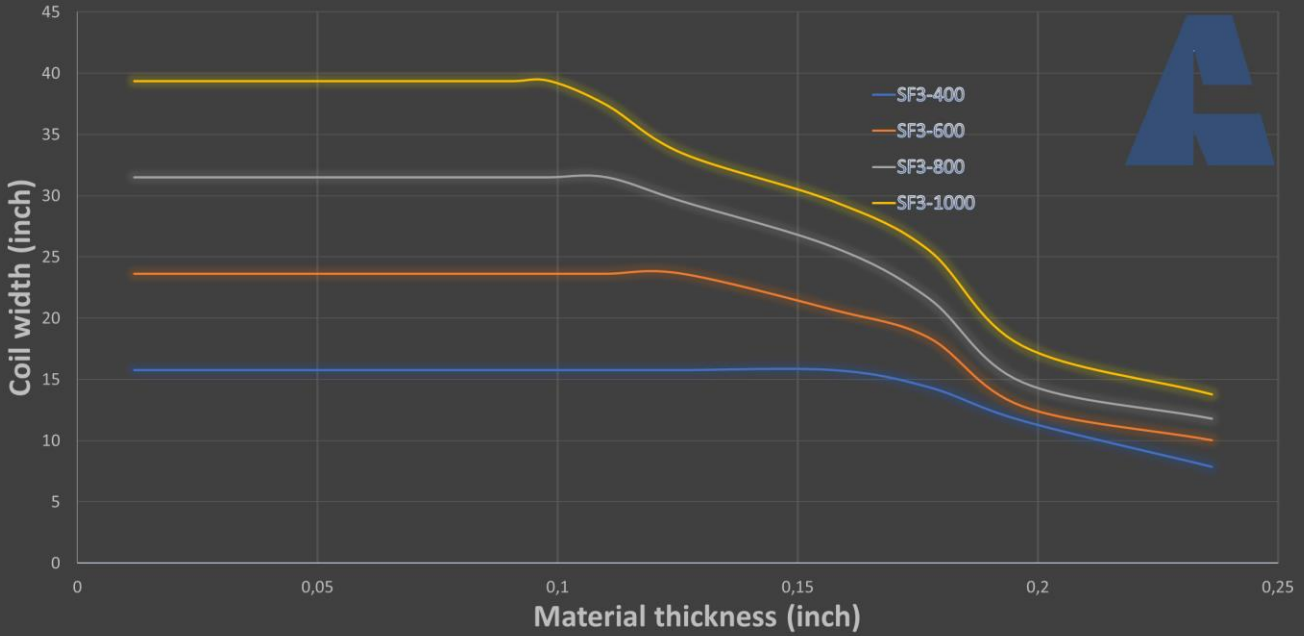

THICKNESS (INCH)	AZ-SF3-400	AZ-SF3-600	AZ-SF3-800	AZ-SF3-1000
0,01	15,75	23,62	31,5	39,37
0,04	15,75	23,62	31,5	39,37
0,05	15,75	23,62	31,5	39,37
0,05	15,75	23,62	31,5	39,37
0,08	15,75	23,62	31,5	39,37
0,09	15,75	23,62	31,5	39,37
0,1	15,75	23,62	31,5	39,37
0,11	15,75	23,62	31,5	37,4
0,13	15,75	23,62	29,53	33,46
0,16	15,75	20,67	25,79	29,53
0,18	14,37	18,43	21,65	25,59
0,2	11,61	12,8	14,76	17,72
0,24	7,87	10,04	11,81	13,78





Advanced feed interface

Our advanced feed interface allows you to store more jobs, sequential feed, GAG capabilities, & more!



Up to 1000 jobs storage with search capabilities.

Each job can store up to 20 sequences with GAG outputs available.

Easily update sequence to your servo feeder from the sequential feed interface.



Complete your line with our uncoiler & control everything from the main screen. Our decoiler output controller allows you to set-up your loop delay easily with our built-in timer controller.





Azimuth turnkey solution

We specialized in complete turnkey press line solution & design, which allows our customer to provide us complete contract in integrating their press solution. We supply & manufacture;

- Presses
- Tooling
- Custom controller solution
- Feed-line
- Safety integration



